



Read this document carefully before using this device. The guarantee will be expired by damaging of the device if you don't attend to the directions in the user manual. Also we don't accept any compensations for personal injury, material damage or capital disadvantages.

ENDA EPA942 PROGRAMMABLE AC/DC AMMETER

Thank you for choosing ENDA EPA942 Programmable AC/DC Ammeter.

- ▶ 96 x 96mm sized.
- ▶ 4 digits display.
- ▶ Easy to use with front panel keypad.
- ▶ Can be used with current transformer or shunt.
- ▶ Programmable scale between 5A and 9999A.
- ▶ Multi-functional alarm output for Lower and Upper limits (NO).
- ▶ Multi-functional alarm setpoints with Alarm Output (NO).
- ▶ Multifunctional alarm output (NO+NC) for upper and lower limits.
- ▶ Communication feature over isolated RS485, using ModBus RTU protocol.(Optional).
- ▶ Measuring type can be selected as AC, DC or true RMS.
- ▶ Key lock feature.
- ▶ CE marked according to European Norms.



Order Code : EPA942 -

1	2	3									

- | | | |
|--|---|--|
| 1 - Output
R.....(Out) Relay
2R.....(Out + ALR) Relay
Blank.....No Relay | 2 - Supply Voltage
230VAC...230V AC
110VAC...110V AC
24VAC.....24V AC
SM.....9-30V DC / 7-24V AC | 3 - Isolated ModBus
RSI.....Isolated ModBus
(Specify at Order). |
|--|---|--|

R^oHS
Compliant



TECHNICAL SPECIFICATIONS

ENVIRONMENTAL CONDITIONS							
Ambient/stroge temperature	0 ... +50°C/-25 ... 70°C						
Max. Relative humidity	80% Relative humidity for temperatures up to 31°C, decreasing linearly to 50% at 40°C.						
Rated pollution degree	According to EN 60529 Front panel : IP65 , Rear panel : IP20						
Height	Max. 2000m						
Do not use the device in locations subject to corrosive and flammable gases.							
ELECTRICAL CHARACTERISTICS							
Supply	230V AC +10% -20%, 50/60Hz or 110V AC +10% -20%, 50/60Hz or 24V AC ±10% , 50/60Hz or optional 9-30V DC / 7-24V AC ±10% SMPS						
Power consumption	Max. 5VA						
Wiring	2.5mm ² screw-terminal connections						
Scale	AC and RMS 0A...9999A (Specified by c.t.r.r parameter. For example:scale is 0A...5A for c.t.r.r=5.00) DC -999A...9999A (Specified by c.t.r.r parameter. For example:scale is -5A...5A for c.t.r.r=5.00)						
Sensitivity	0.001A x (c.t.r.r /5) (For example , 0.001A for c.t.r.r=5.00)						
Accuracy	AC ± 1% (full scale) (± 2% For square wave form) DC ± 1% (full scale) RMS ± 1% (full scale) (± 2% For square wave form)						
Input Range	<table border="1" style="display: inline-table; border-collapse: collapse;"><tr><td style="padding: 2px;">13</td><td style="padding: 2px;">&</td><td style="padding: 2px;">14</td></tr><tr><td style="padding: 2px;">12</td><td style="padding: 2px;">&</td><td style="padding: 2px;">15</td></tr></table> -5A...5A (Device may be damaged at 10A and above currents) -60mV...60mV (Device may be damaged at 50V and above voltages)	13	&	14	12	&	15
13	&	14					
12	&	15					
Input Impedance	<table border="1" style="display: inline-table; border-collapse: collapse;"><tr><td style="padding: 2px;">13</td><td style="padding: 2px;">&</td><td style="padding: 2px;">14</td></tr><tr><td style="padding: 2px;">12</td><td style="padding: 2px;">&</td><td style="padding: 2px;">15</td></tr></table> 12mΩ 40kΩ	13	&	14	12	&	15
13	&	14					
12	&	15					
Frequency Range	DC , 10Hz - 200Hz (10Hz - 70Hz For square wave form)						
EMC	EN 61326-1: 2013						
Safety requirements	EN 61010-1: 2010 (Pollution degree 2, overvoltage category II)						

OUTPUTS	
Alarm output	2 Relays: 250V AC, 10A (for resistive load), NO.
Life expectancy for relay	Mechanical 30.000.000 ; Electrical 100.000 operation.

HOUSING	
Housing type	Suitable for flush-panel mounting.
Dimensions	W96xH96xD50mm
Weight	Approx. 410g (after packing)
Enclosure material	Self extinguishing plastics.

While cleaning the device, solvents (thinner, gasoline, acid etc.) or corrosive materials must not be used.



SİSEL MÜHENDİSLİK ELEKTRONİK SAN. VE TİC. A.Ş.
Şenifali Mah. Barbaros Cad. No:18 Y.Dudullu 34775
ÜMRANİYE/İSTANBUL-TURKEY
Tel : +90 216 499 46 64 Pbx. Fax : +90 216 365 74 01
url : www.enda.com.tr



DIMENSIONS



Panel Cut-out

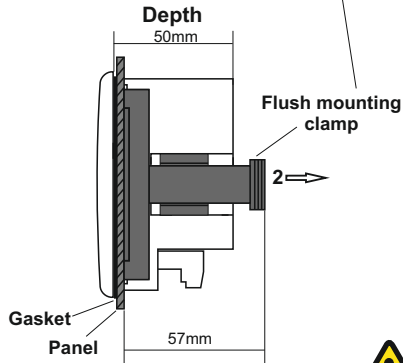
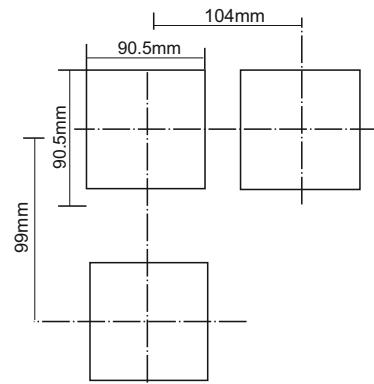

For removing mounting clamps :

- Push the flush-mounting clamp in direction 1 as shown in the figure left.
- Then, pull out the clamp in direction 2.

- 1) Panel thickness should be maximum 10mm.
- 2) There must be at least 60mm free space behind the device, otherwise it would be difficult to remove it from the panel.

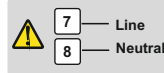

CONNECTION DIAGRAM

ENDA EPA942 is intended for installation in control panels. Make sure that the device is used only for intended purpose. The electrical connections must be carried on by a qualified staff and must be according to the relevant locally applicable regulations. During an installation, all of the cables that are connected to the device must be free of electrical power. The device must be protected against inadmissible humidity, vibrations and severe soiling. Make sure that the operation temperature is not exceeded. The cables should not be close to the power cables or



CAUTION :

If 5A and 60mV inputs are connected at the same time, the measurement will be incorrect.

NOTE :

SUPPLY:



Fuse should be connected.

Cable size: 1,5mm²

- 1) Mains supply cords shall meet the requirements of IEC 60227 or IEC 60245.
- 2) In accordance with the safety regulations, the power supply switch shall bring the identification of the relevant instrument and it should be easily accessible by the operator.

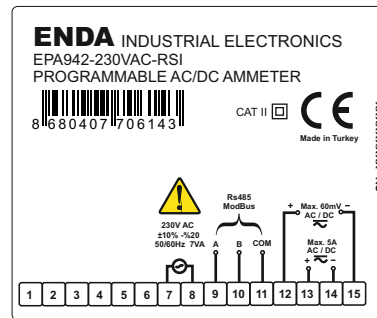
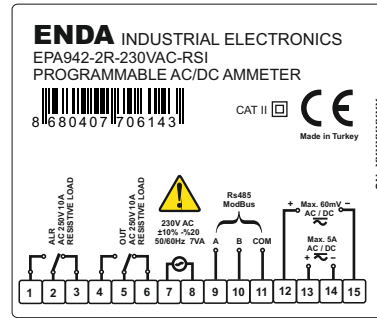

ALARM OUTPUT CHART

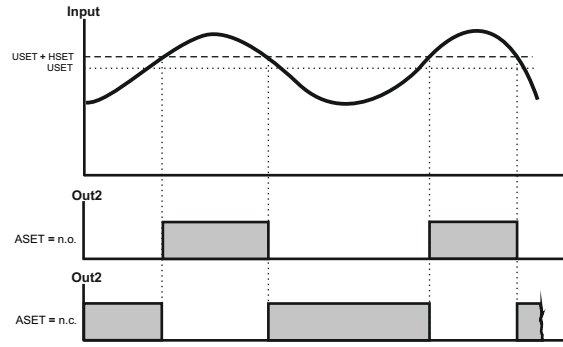

OUTPUT CHART

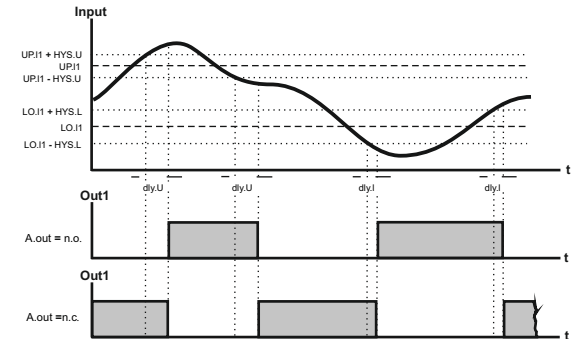

	ac	dc	Ac.dc (rms)
	$A \frac{1}{\sqrt{2}}$	0.000	$A \frac{1}{\sqrt{2}}$
	0.308 A	$A \frac{2}{\pi}$	$A \frac{1}{\sqrt{2}}$
	0.386 A	$A \frac{1}{\pi}$	$A \frac{1}{2}$
	A	0.000	A
	$A \frac{1}{2}$	$A \frac{1}{2}$	$A \frac{1}{\sqrt{2}}$
	$A \sqrt{\frac{d}{T} - \frac{d^2}{T^2}}$	$A \frac{d}{T}$	$A \sqrt{\frac{d}{T}}$
	$A \frac{1}{\sqrt{3}}$	0.000	$A \frac{1}{\sqrt{3}}$

Equipment is protected throughout by DOUBLE INSULATION

Holding screw 0.4-0.5Nm.



EPA942 PROGRAMMING DIAGRAM

Incrment Key		Used for increasing the setpoint value and changing parameters. When held down for a few seconds, configured numeric value increases faster.
Decrement Key		Used for decreasing the setpoint value and changing parameters. When held down for a few seconds, configured numeric value increases faster.
Programming Key		Used for displaying and configuring the selected parameter value.
Lock / Unlock Keypad		Locks / Unlocks keypad.

SETTING UP THE PARAMETERS



- If key is pressed, the current value of the parameter appears by flashing on the display.
- By using "UP" or "DOWN" navigation keys, selected parameter can be adjusted to the desired value.
- After the setting up the parameters, if set key is pressed again, adjusted parameter name appears on display.

If these keys are pressed and held for 3 seconds, "Programming Mode" is entered or it returns to "Running Mode".
If and keys are pressed while parameter names are displayed, than it returns to measured value.

PROGRAMMING MODE

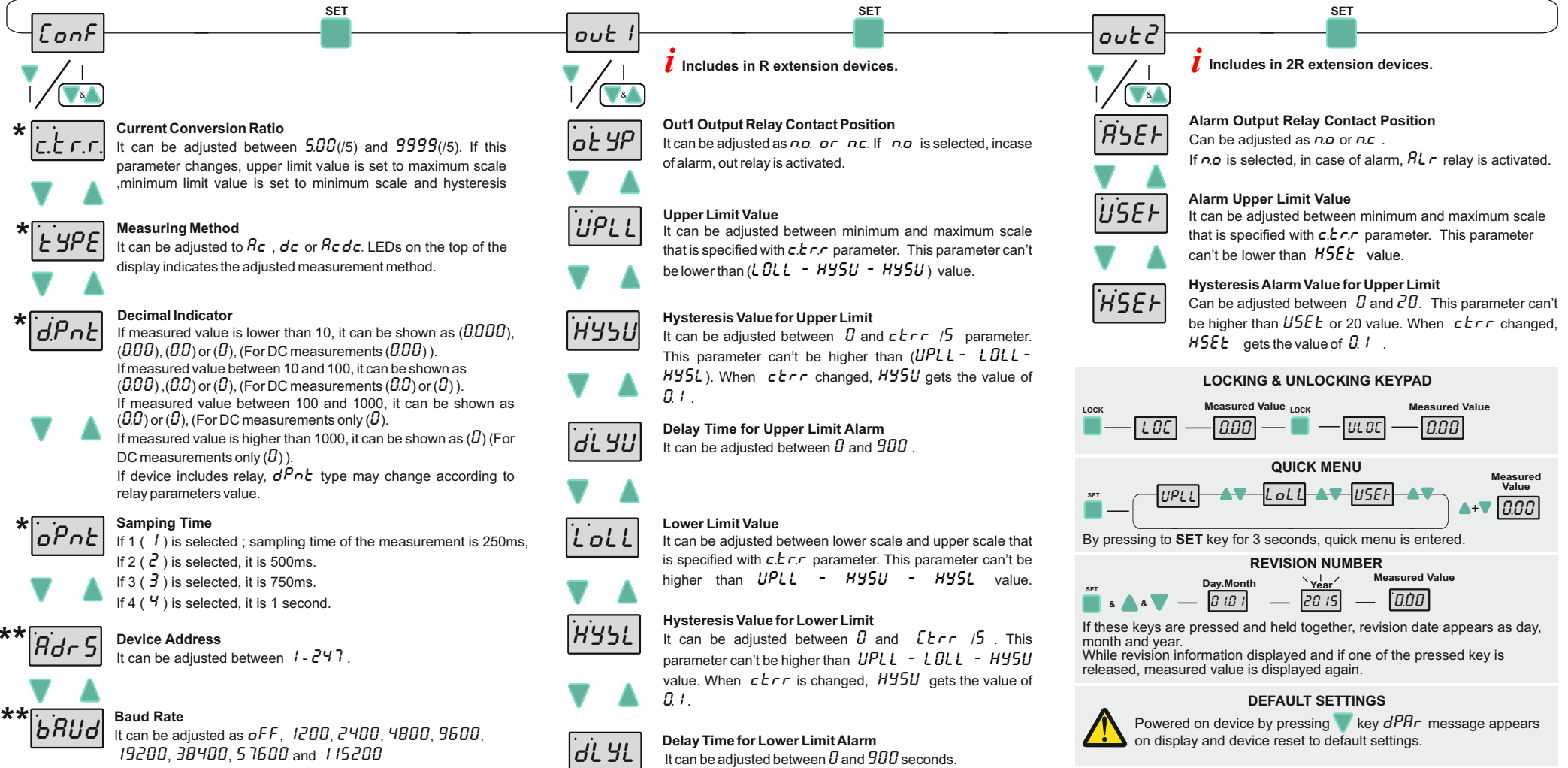

LOCKING & UNLOCKING KEYPAD

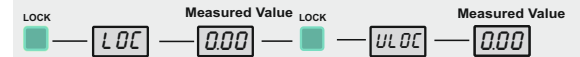

QUICK MENU

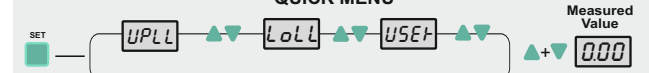

By pressing to **SET** key for 3 seconds, quick menu is entered.

REVISION NUMBER

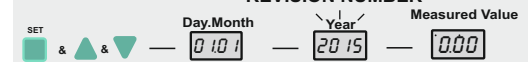

If these keys are pressed and held together, revision date appears as day, month and year.
While revision information displayed and if one of the pressed key is released, measured value is displayed again.

DEFAULT SETTINGS

Powered on device by pressing key *dPnt* message appears on display and device reset to default settings.

ERROR MESSAGES

Measured current value is higher than maximum scale.

Measured current value is lower than minimum scale.

(*) *cErr*, *TYPE*, *dPnt* and *oPnt* parameters are available for only that devices have no relays.

(**) *AdrS* and *bAUd* parameters are available for only that devices have ModBus.

ENDA EPA942 DIGITAL AMPERMETER MODBUS PROTOCOL ADDRESS MAP

HOLDING REGISTERS FOR R EXTENSION DEVICES

Holding Register Addresses		Data Type	Data Content	Parameter Name	Read/Write Permission	Status Value
Decimal	Hex					
0000d	0x0000	word	Alarm Output Relay Contact Position	<i>DTYP</i>	Readable/Writable	<i>no</i>
0001d	0x0001	word	Current change ratio.	<i>ctrr</i>	Readable/Writable	<i>5</i>
0002d	0x0002	word	The upper limit of the setpoint	<i>UPLL</i>	Readable/Writable	<i>5.000</i>
0003d	0x0003	word	The upper limit of the hysteresis value	<i>HYSU</i>	Readable/Writable	<i>0.100</i>
0004d	0x0004	word	Delay time for the upper limit alarm	<i>dLYU</i>	Readable/Writable	<i>0</i>
0005d	0x0005	word	The lower limit of the setpoint	<i>LOLL</i>	Readable/Writable	<i>0.000</i>
0006d	0x0006	word	The lower limit of the hysteresis value	<i>HYSL</i>	Readable/Writable	<i>0.100</i>
0007d	0x0007	word	Delay time for the lower limit alarm	<i>dLYL</i>	Readable/Writable	<i>0</i>
0008d	0x0008	word	Measurement method (<i>0=AC, 1=dC, 2=ACdC</i>)	<i>TYPE</i>	Readable/Writable	<i>ACdC</i>
0009d	0x0009	word	Decimal point. (<i>0=X, 1=X.X, 2=X.XX, 3=X.XXX</i>)	<i>dPnt</i>	Readable/Writable	<i>0.000</i>
0010d	0x000A	word	Sampling time of the measurement value. If 1 is selected, it is 250ms. If 2 is selected, it is 500ms. If 3 is selected, it is 750ms. If 4 is selected, it is 1 second.	<i>oPtn</i>	Readable/Writable	<i>4</i>
0011d	0x000B	word	Device address for RS485 network connection. Adjustable between 1-247.	<i>AdRS</i>	Readable/Writable	<i>1</i>
0012d	0x000C	word	Baudrate (<i>0=Off; 1=1200; 2=2400; 3=4800; 4=9600; 5=19200; 6= 38400; 7= 57600; 8= 115200</i>)	<i>bAUD</i>	Readable/Writable	<i>oFF</i>

*HOLDING REGISTER PARAMETER TABLE (NO RELAY MODELS)

0000d	0x0000	word	Current change ratio.	<i>ctrr</i>	Readable/Writable	<i>5</i>
0001d	0x0001	word	Measurement method (<i>0=AC, 1=dC, 2=ACdC</i>)	<i>TYPE</i>	Readable/Writable	<i>ACdC</i>
0002d	0x0002	word	Decimal point. (<i>0=X.XX, 1=X.X, 2=X</i>)	<i>dPnt</i>	Readable/Writable	<i>0.00</i>
0003d	0x0003	word	Sampling time of the measurement value	<i>oPtn</i>	Readable/Writable	<i>4</i>
0004d	0x0004	word	Device address for RS485 network connection. Adjustable between 1-247.	<i>AdRS</i>	Readable/Writable	<i>1</i>
0005d	0x0005	word	Baudrate (<i>0=Off; 1=1200; 2=2400; 3=4800; 4=9600; 5=19200; 6= 38400; 7= 57600; 8= 115200</i>)	<i>bAUD</i>	Readable/Writable	<i>oFF</i>

INPUT REGISTERS FOR R EXTENSION DEVICES

Input Register Addresses		Data Type	Data Content	Parameter Name	Read/Write Permission
Decimal	Hex				
0000d	0x0000	word	Measured current value	--	Only Readable

DISCRETE INPUTS FOR R EXTENSION DEVICES

Discrete Input Addresses		Data Type	Data Content	Parameter Name	Read/Write Permission
Decimal	Hex				
0000d	0x0000	Bit	Relay output state (<i>0=oFF; 1=on</i>)	--	Only Readable

COILS FOR R EXTENSION DEVICES

Coil Addresses		Data Type	Data Content	Parameter Name	Read/Write Permission	Status Value
Decimal	Hex					
0000d	0x0000	Bit	Out1 Output Relay Contact Position (<i>0=no; 1=nc</i>)	<i>DTYP</i>	Readable/Writable	<i>no</i>
0001d	0x0001	Bit	Alarm Output Relay Contact Position (<i>0=no; 1=nc</i>)	<i>RSEt</i>	Readable/Writable	<i>no</i>

* Coil and Discrete input parameters are not available that devices have no relays.

Note 1 : *DTYP* and *RSEt* menu parameters can be used as "Holding Register" or "Coil".

Note 2 : Received "ModBus input register value" is multiplying by 1000 (based on *dPnt*) and mA value reached. For example ;

if modbus value is 2842, (for *dPnt* = 2 (*0.00*)) $28.42 \times 1000 = 28420$ mA, ie 28.42A

if modbus value is 2842, (for *dPnt* = 3 (*0.000*)) $2.842 \times 1000 = 2842$ mA, ie 2.842A



ENDA EPA542-xx-x-xxx-RSI INPUT REGISTERS DEVICES

Holding Register Addresses		Data Type	Data Content	Parameter Name	Read/Write Permission	Status Value
Decimal	Hex					
0000d	0x0000	word	Alarm Output (OUT) Relay Contact Position	<i>OUTYP</i>	Readable/Writable	<i>no</i>
0001d	0x0001	word	Alarm Output (OUT) Relay Contact Position	<i>ASET</i>	Readable/Writable	<i>no</i>
0002d	0x0002	word	Current change ratio.	<i>CTRR</i>	Readable/Writable	<i>5</i>
0003d	0x0003	word	The upper limit of the setpoint	<i>UPLL</i>	Readable/Writable	<i>5.000</i>
0004d	0x0004	word	The upper limit of the hysteresis value	<i>HYSU</i>	Readable/Writable	<i>0.100</i>
0005d	0x0005	word	Delay time for the upper limit alarm	<i>DLYU</i>	Readable/Writable	<i>0</i>
0006d	0x0006	word	The lower limit of the setpoint	<i>LOLL</i>	Readable/Writable	<i>0.000</i>
0007d	0x0007	word	The lower limit of the hysteresis value	<i>HYSL</i>	Readable/Writable	<i>0.100</i>
0008d	0x0008	word	Delay time for the lower limit alarm	<i>DLYL</i>	Readable/Writable	<i>0</i>
0009d	0x0009	word	Alarm Upper Limit Value	<i>USEL</i>	Readable/Writable	<i>5.000</i>
0010d	0x000A	word	Hysteresis Alarm Value for Upper Limit	<i>HSEL</i>	Readable/Writable	<i>0.100</i>
0011d	0x000B	word	Measurement method (0=AC, 1=dC, 2=ACdC)	<i>TYPE</i>	Readable/Writable	<i>ACdC</i>
0012d	0x000C	word	Decimal point. (0=X, 1=X.X, 2=X.XX, 3=X.XXX)	<i>dPnt</i>	Readable/Writable	<i>0.000</i>
0013d	0x000D	word	Measurement period. If 1 is selected, it is 250ms. If 2 is selected, it is 500ms. If 3 is selected, it is 750ms. If 4 is selected, it is 1 second.	<i>oPtn</i>	Readable/Writable	<i>4</i>
0014d	0x000E	word	Device address for RS485 network connection. Adjustable between 1-247.	<i>Adr5</i>	Readable/Writable	<i>1</i>
0015d	0x000F	word	Baudrate (0=Off;1=1200;2=2400;3=4800;4=9600;5=19200 6= 38400; 7= 57600; 8= 115200)	<i>baud</i>	Readable/Writable	<i>oFF</i>

INPUT REGISTERS FOR 2R EXTENSION DEVICES

Input Register Addresses		Data Type	Data Content	Parameter Name	Read/Write Permission
Decimal	Hex				
0000d	0x0000	word	Measured current value	--	Only Readable

DISCRETE INPUTS FOR 2R EXTENSION DEVICES

Discrete Input Addresses		Data Type	Data Content	Parameter Name	Read/Write Permission
Decimal	Hex				
0000d	0x0000	Bit	Relay output state (0=OFF; 1=on)	--	Only Readable

COILS FOR 2R EXTENSION DEVICES

Coil Addresses		Data Type	Data Content	Parameter Name	Read/Write Permission	Status Value
Decimal	Hex					
0000d	0x0000	Bit	Out1 Output Relay Contact Position (0=no; 1=nc)	<i>OUTYP</i>	Readable/Writable	<i>no</i>
0001d	0x0001	Bit	Alarm Output Relay Contact Position (0=no; 1=nc)	<i>ASET</i>	Readable/Writable	<i>no</i>

Note 1 : *OUTYP* and *ASET* menu parameters can be used as “Holding Register” or “Coil”.

Note 2 : Received "ModBus input register value" is multiplying by 1000 (based on *dPnt*) and mA value reached. For example ;

if modbus value is 2842, (for *dPnt* = 2 (0.00)) 28.42x1000 = 28420 mA, ie 28.42A

if modbus value is 2842, (for *dPnt* = 3 (0.000)) 2.842x1000 = 2842 mA, ie 2.842A