

OCM-01 and OCM-03

OVER CURRENT MONITORING DEVICES

- ▶ Over Current Adjustment (0,5 – 5 A) OCM-01
- ▶ Over Current Adjustment (2 – 100 A with current transformer) OCM-03
- ▶ Start Delay Time (1 – 6 sec)
- ▶ Delay Time (0,5 – 3 sec)

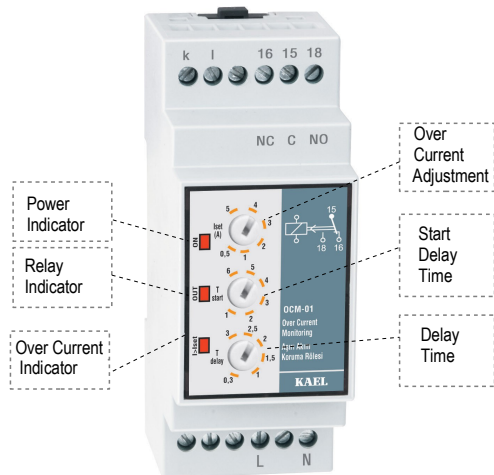

General:

OCM-01 and OCM-03 Over Current Monitoring Devices protects motors and the system they are connected.

If the measured current of a motor or a system less than adjusted overcurrent value, "relay indicator" turns on. When the measured current exceeds adjusted overcurrent value, relay indicator turns off and relay contact would be open circuit after delay time.

Over-Current Adjustment : Over current value could be set between 0,5 and 5A. It is the desired over current value for protection of a motor or a system. The hysteresis value is %3.

Start Delay Time Adjustment T(s) : Start delay time could be set between 1 and 6 seconds. After the motors start to run, they draw high current within a short time and the measured current value could exceed the adjusted over current value. To avoid the operation failure during this time, the device would not energize the relay. After start delay time the current would be measured.

Delay Time Adjustment T(d) : Delay time could be set between 0,5 and 3 seconds. When the measured current exceeds adjusted overcurrent value, relay contact would be open circuit after delay time and motor would be deenergized. If the measured current value falls below the limit during this time, delay time would be reset.

Warning Indicators:

ON (Power) : Turns on, if the device is powered.

OUT (Relay) : Turns on, if the relay contact is short circuit.

I>set : When the measured current exceeds adjusted overcurrent value, LED flashes during delay time. At the end of the delay time it turns on continuously.

WARNINGS

- 1- Please do not open the device panel. There is no user serviceable parts inside the device.
- 2- Before making the connections to device's terminals, please be sure that there is no voltage across the cables or terminals. Also be sure that the panel is de-energized.
- 3- Before cleaning the device, please be sure that it is de-energized and use only dry tissue-paper to clean it. Water or any other chemicals used for cleaning may harm the device
- 4- Before commissioning the device, please be sure that the terminal connections are made exactly the same as in the connection diagram and so as not to cause contact problems.
- 5- Contact your authorized dealer, if a problem occurs with your device.
- 6- Following the precautions is to prevent the users from physically and spiritual damage. KAEL Elektronik Ltd. Şti. or dealer is not responsible for any injuries or damages due to violation of the warnings.

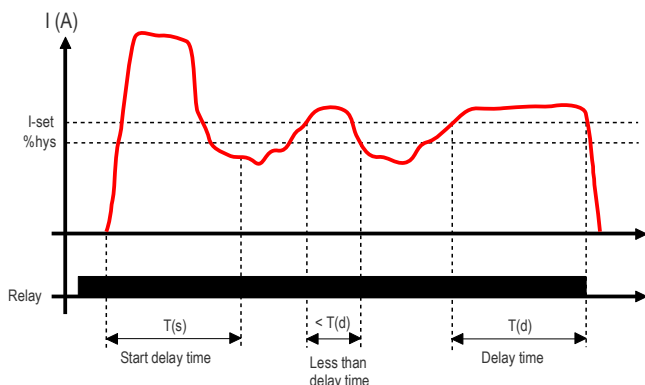

CONNECTIONS

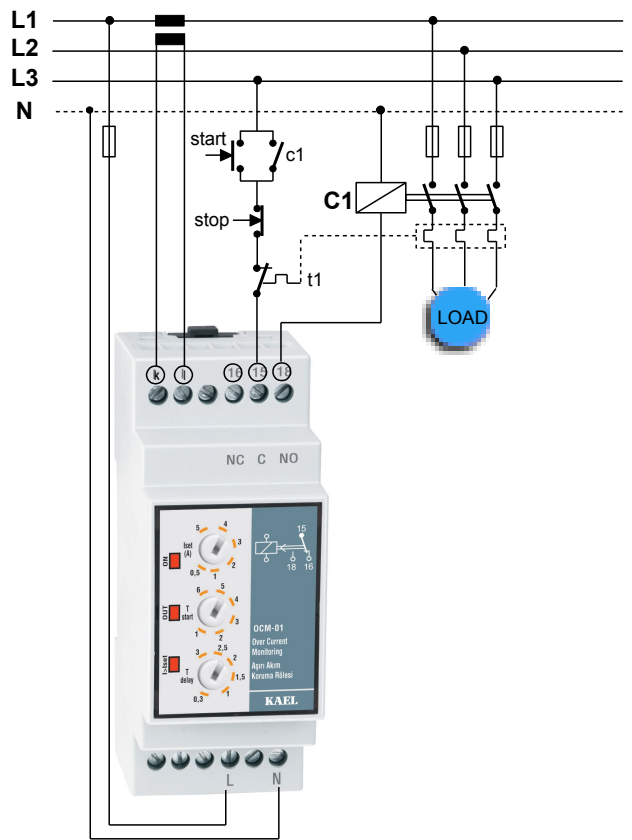

PROTECTION CASES BY CONNECTION:

- ▶ **If L1 phase disconnected** The device would be deenergized and the relay contact would be released immediately.
- ▶ **If L2 phase disconnected** Excessive current flows through the current transformer and relay contact would be released at the end of the delay time.
- ▶ **If L3 phase disconnected** Excessive current flows through the current transformer and relay contact would be released at the end of the delay time.
- ▶ **If N disconnected** ; The device would be deenergized and the relay contact would be released immediately.

TECHNICAL DATA

Rated Voltage (Un)	: 230 Vac
Operating Range	: (0,9 – 1,1) x Un (Un nominal voltage)
Frequency	: 50/60 Hz
Current Adjustment Range	: OCM-01 ; 0,5 – 5 A OCM-03 ; 2 – 100A with current transformer
Start Delay Time	: 1 – 6 sn
Delay Time	: 0,5 – 3 sn
Contact Current	: Max.5 A / 240 Vac
Power Consumption	: < 4 VA
Device Protection Class	: IP20
Ambient Temperature	: - 5 °C...+ 50 °C
Connection Type	: To connection rail in electrical panel
Dimensions	: 35x90x58 mm

